

innovation in irrigation™

NELSON**SR/SRA150 BIG GUN®****SR/SRA150 BIG GUN® OPERATION AND MAINTENANCE INSTRUCTIONS****SET UP FOR OPERATION:**

1. Install nozzle. If using ring nozzle set, or taper ring nozzle, install desired ring size in ring nozzle cap. Assure the ring is centered. The ring nozzle cap can be sufficiently tightened by hand.
2. Adjust location of arc stops to give desired arc of coverage. Stops must be mounted so that arrows point toward each other and the trip lever is located between arrows. If the stops are set incorrectly on the wrong end of the arc, the sprinkler will fail to reverse.
3. The SR150 and SRA150 are factory set for normal rotation speed. If a faster or slower speed is desired, move arm weight backward for faster operation or forward for slower operation.
4. To vary the trajectory angle of the SRA150 simply adjust the turn-buckle and dial in the desired trajectory using the calibrated scale. Varying trajectory angle is simple, and can be used to increase wind-fighting ability or to avoid obstacles such as power lines in the field.

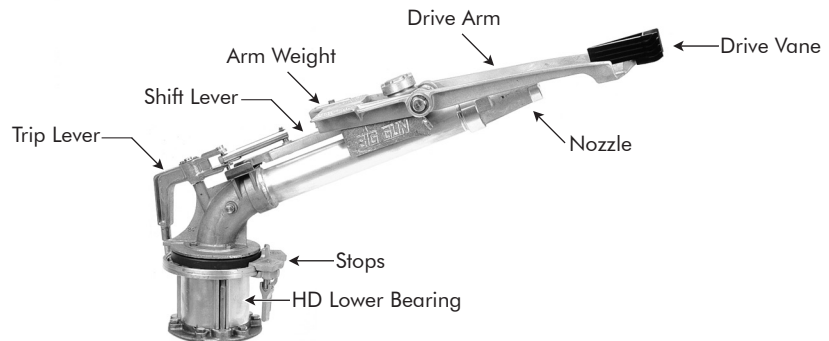

The **SR150** is available in fixed trajectory angles of **21°, 24°, 27°** and **43°**. A trajectory modification using a 12° wedge kit #11237 is available.

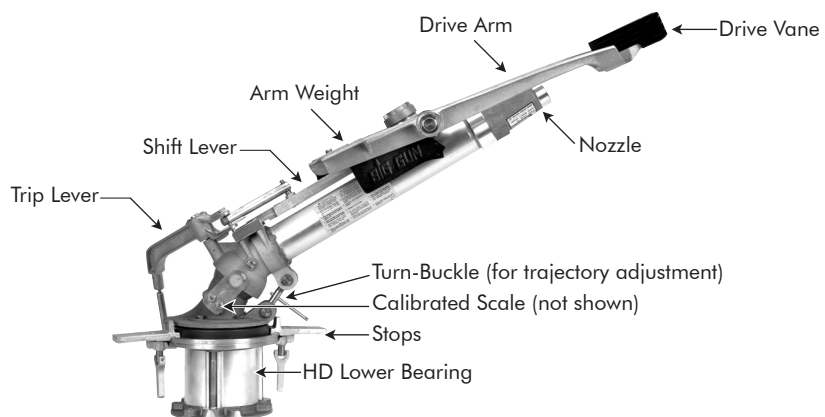

The **SRA150** is a variable trajectory model with adjustability from **15-45°**.

NOTE ON LUBRICATION: The SR/SRA150 sprinkler is lifetime lubricated and does not require periodic lubrication. The ball bearings in the H.D. lower bearing operate in a water resistant lubricant that is packed in the housing cavities and retained by seals. If repair of the lower bearing is done, it is recommended to use Nelson #6143 lubricant or a good grade of water resistant lubricant such as Lubriplate 130-AA.

BE CAREFUL: Read operating instructions before operating sprinkler or making any adjustments. Never make adjustments or perform service while sprinkler is in operation. Stand clear of operating sprinkler. Stand clear of high velocity water stream. Never direct water stream onto roadway or electrical transmission lines.

WARRANTY AND DISCLAIMER

Nelson Big Gun® Sprinklers are warranted for one year from date of original sale to be free of defective materials and workmanship when used within the working specifications for which the product was designed under normal use and service. The manufacturer assumes no responsibility for installation, is limited solely to replacement or repair of defective parts, and the manufacturer will not be liable for any crops or other consequential damages resulting from any defects or breach of warranty. THIS WARRANTY IS EXPRESSLY IN LIEU OF ALL OTHER WARRANTIES, EXPRESS OR IMPLIED, INCLUDING THE WARRANTIES OF MERCHANTABILITY AND FITNESS FOR PARTICULAR PURPOSES AND OF ALL OTHER OBLIGATIONS OR LIABILITIES OF MANUFACTURER. No agent, employee or representative of the manufacturer has authority to waive, alter or add to the provision of the warranty, nor to make any representations or warranty not contained herein.

SEE SR/SRA150 PARTS LISTS FOR COMPLETE PARTS LIST AND DESCRIPTION

DISASSEMBLY

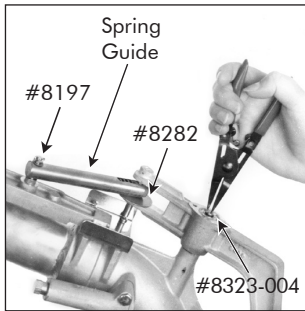

STEP 1 (Trip Lever)

Remove #6714 Cotter Pin from #8197 Pin. Remove two #8311 Screws and #8263 Cap. Using small retaining ring pliers, remove #8323-004 Retaining Ring. Pull entire trip lever assembly and spring guide from gun. At this time inspect wear on #8282 Follower. Replace if worn.

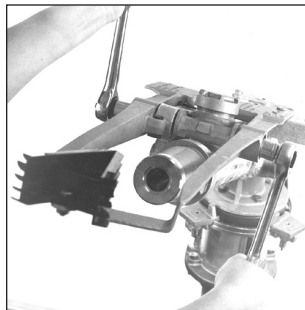

STEP 2 (Drive Arm)

Using internal retaining ring pliers, remove two #6565 Retaining Rings from both arm hubs. Remove two #10067-001 Arm Caps. Using two 11/16" sockets, loosen and remove one #6603 Nut from left side of arm. Holding the opposite #6603 Nut, pull shaft free from hub.

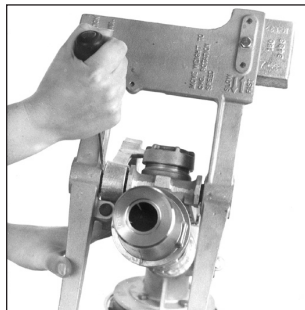

STEP 3

Using a thin-bladed screwdriver, push #8327-001 Spacer back into arm hub. Holding onto counterweight, remove arm and weight. Be careful not to damage seals.



STEP 4

Inspect seal spacer and counterweight spacer for wear. If spacers show excessive wear, replace both spacers and #6600 Seals. To remove seals, drive thin-bladed screwdriver under lip of seal and pry seal out. To replace seals, use block of wood over seal making sure lip is to the outside, and secure by lightly tapping on wooden block until seal lip is flush with hub.



STEP 5

Remove #10070-001 Cap Assembly. Using external retaining ring pliers, remove #8323-017 Retaining Ring. Pull Shift lever from mount. A gear puller will help in removing the lever.

REASSEMBLY

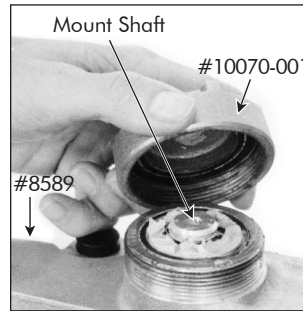

STEP 6 (Shift Lever)

At the upper portion of the gun, inspect the mount shaft for wear. Press the #8589 Shift Lever assembly onto the mount. With external retaining ring pliers, snap the #8323-017 Retaining Ring on. Be sure #8272 Cap Gasket is in place and in good condition. Replace #10070-001 Cap Assembly

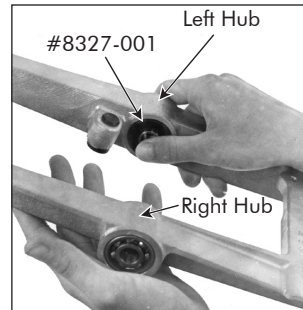

STEP 7 (Drive Arm)

Lubricate #6600 Seal lips with #9673 Silicone Grease. Install #8327-001 Spacer flush with #6600 Seal in left arm hub. Insert #6607-001 (coated spacer) in right arm hub and #6607 (uncoated spacer) in left counterweight seal (or a second #6607-001 coated spacer). Start #8297 Shaft into right arm hub.

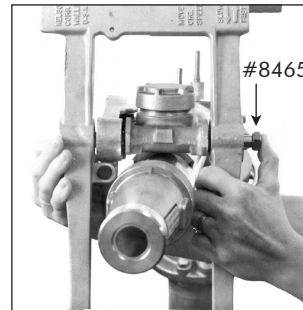

STEP 8

Holding counterweight in place on the left side of shift lever, roll drive arm into position shown by pushing on the left arm bearing. Work #8327-001 Spacer into seal on counterweight. Be sure spacer is correctly positioned in counterweight to prevent cutting of the seal lip. Push shaft through the bearings and spacers and assemble #6603 Nut. Torque to 25 ft. lbs. using two 11/16" sockets.

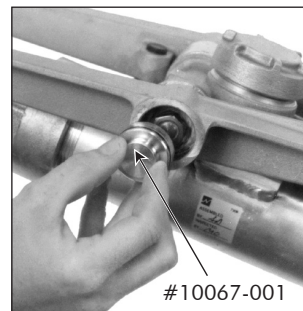

STEP 9

Snap in two #10067-001 Arm Cap Assemblies. Install two #6565 Retaining Rings. Arm must have free movement at this point. If arm feels sticky, assure that lip seals at counterweight and right arm hub are not rubbing on each other.



STEP 10

Mount trip lever assembly along with spring guide onto their respective pins. Install #8323-04 Retaining Ring. Install #8263 Cap using two #8311 Screws making sure #8265 gasket is in place. Install #8409 Washer and #7814 Cotter Pin onto spring guide.

SEE BACK PAGE FOR PARTS LIST

DISASSEMBLY (LOWER UNIT)

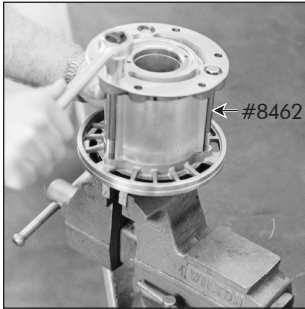

STEP 11
 After removing bearing from gun, insert two 5/16-18" #8408 Bolts into shaft top. Clamp bolt heads into a vise securely. Remove three #8462 Bolts (or #10153-001 for ANSI/DIN).

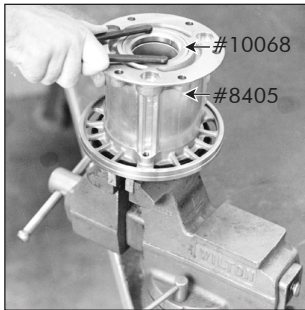

STEP 12
 The #10068 Retainer Assembly is removed by using a spanner wrench with unit still bolted into vise. NOTE: An extension handle on the spanner wrench may be needed to loosen the retainer. Remove retainer and flange, and slide #8405 Housing from bearing shaft.

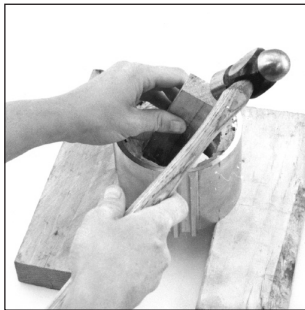

STEP 13
 Remove the #8373 Seal. To remove the two #6253 Bearings use a hammer and three blocks of wood. Lightly tap uniformly around inner race of bearing until removed. Bearings are removed from opposite sides of the #8405 Housing.

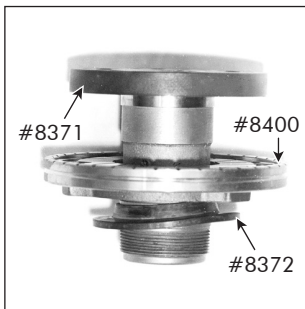

STEP 14
 Remove #8400 Cover from shaft. Remove #8372 Seal from cover. Remove #8371 brake ring and #8473 dust seal from shaft.

Inspect all parts for wear and replace as required.

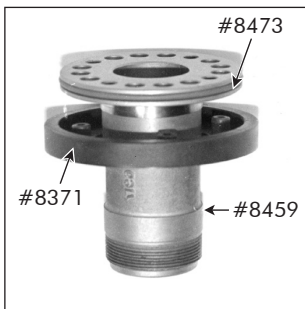

STEP 15
 Assemble #8473 Dust Seal onto #8459 Shaft Assembly. Slide #8371 Brake Ring onto shaft. Locate the four studs of the brake ring in the center holes between the smaller threaded holes.

REASSEMBLY (LOWER UNIT)

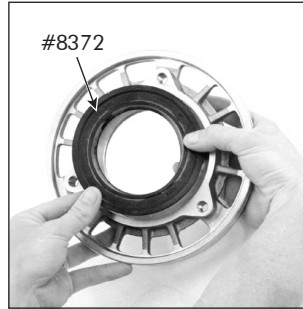

STEP 16
 Place #8372 Lip Seal into #8400 cover as shown with Nelson name toward ball bearing. Pack #6253 Bearing with #6143 lubricant or equivalent. (See "Notes on Lubrication" on the front cover.) Press bearing into #8400 Cover. Slide cover assembly onto bearing shaft. CAUTION: Do not get grease on brake surface.



STEP 17
 Assemble #8461 Gasket. Press on #8405 Housing. Fully pack housing with #6143 Lubricant. Assemble #6253 Bearing into housing.



STEP 18
 Install #6548 O-Ring in #8402 Retainer and assemble retainer on shaft. Using method described in disassembly (Lower Unit) instructions Step 12, secure bearing shaft from rotating. Torque on #10068 Retainer Assembly to 100-120 ft. lbs. Assemble #8373 Lip Seal. Orient with lip side out.

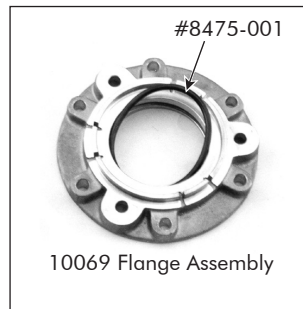

STEP 19
 Assemble #8461 Gasket. Install #8475-001 O-Ring in Flange and mount onto assembly using three #8462 Bolts. Torque bolts to 130-150 in. lbs.



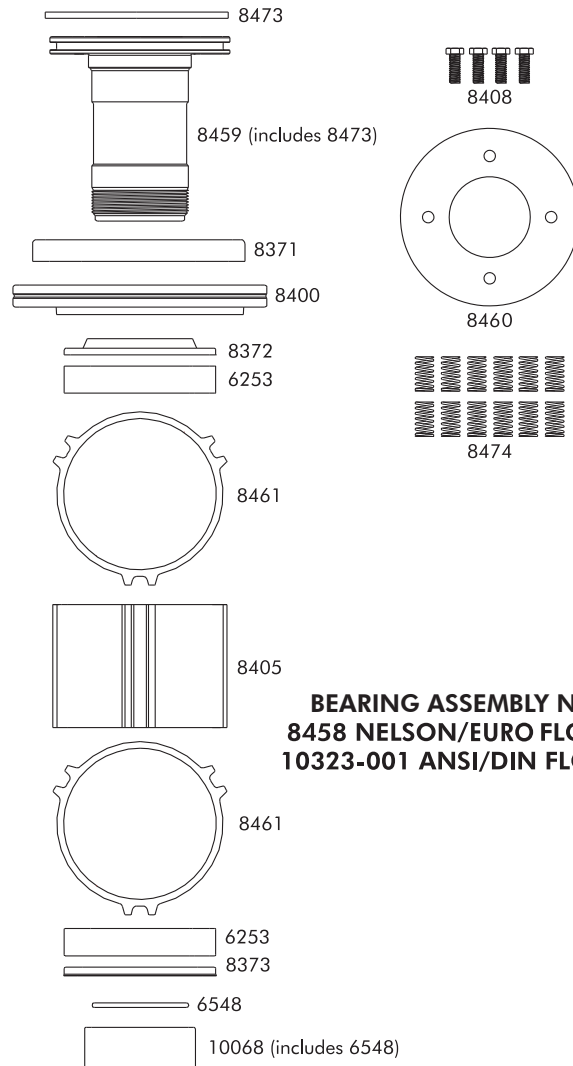

BEARING ASSEMBLY NUMBER
8458 NELSON/EURO FLG. CONN.
10323-001 ANSI/DIN FLG. CONN.

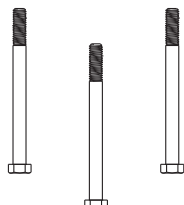
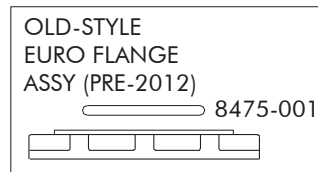
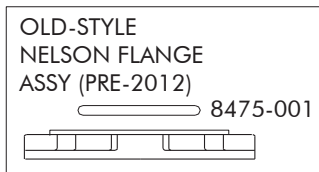
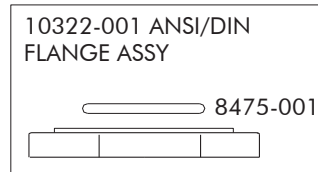
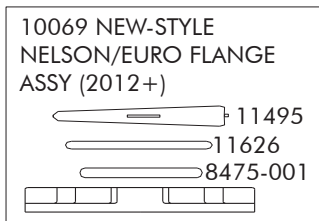

SCREWS		
NELSON FLANGE	EURO FLANGE	ANSI/DIN FLANGE
8462	8462	10153-001

SEE SR150/SRA150 PARTS LISTS
 FOR DETAILS ON OTHER PARTS